

Turmdrehkran 630 EC-H 50

Tower Crane / Grue à tour / Gru a torre
Grúa torre / Guindaste de torre

630 EC-H 40
630 EC-H 40 Litronic®
▶ **630 EC-H 50**

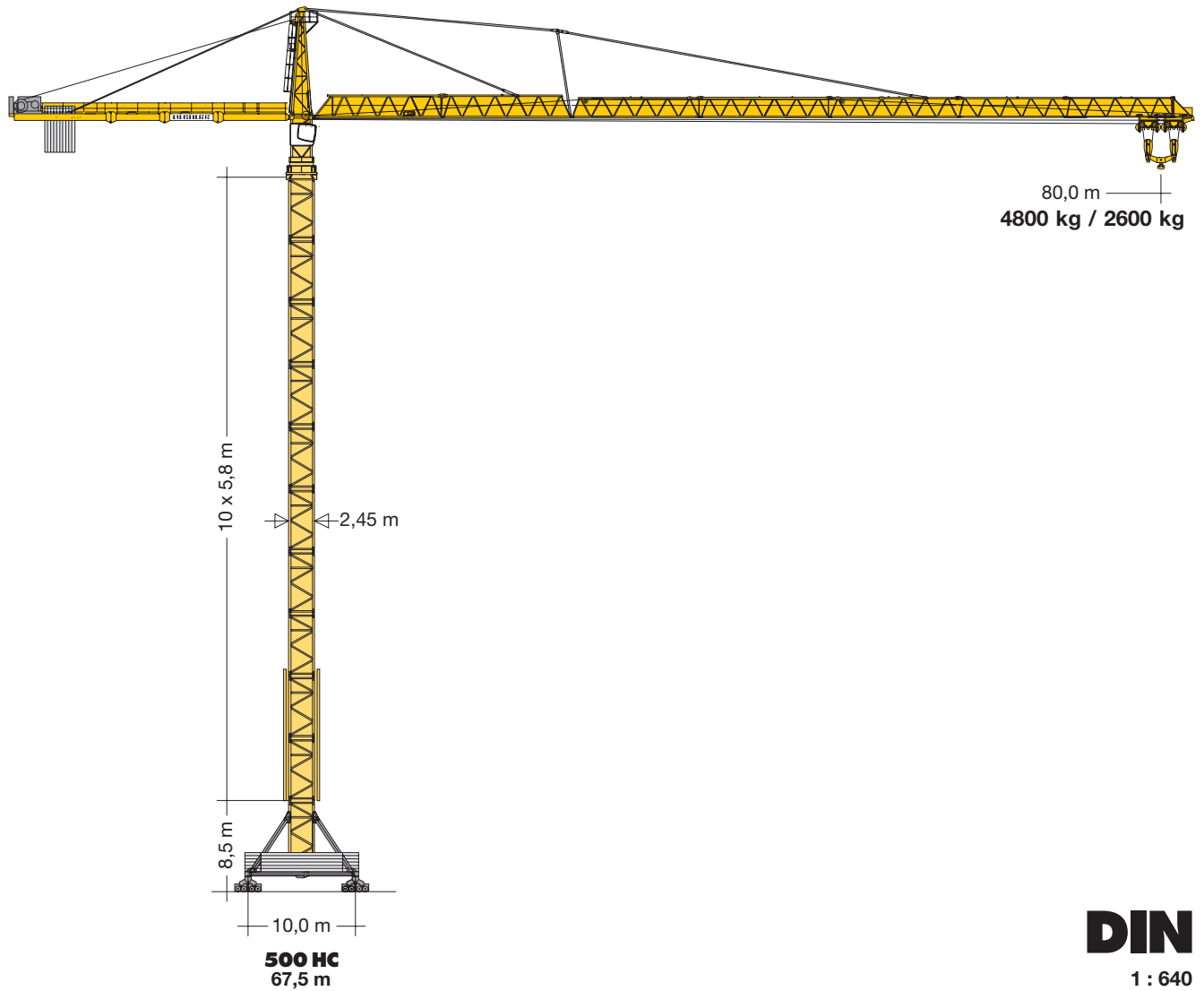

LIEBHERR

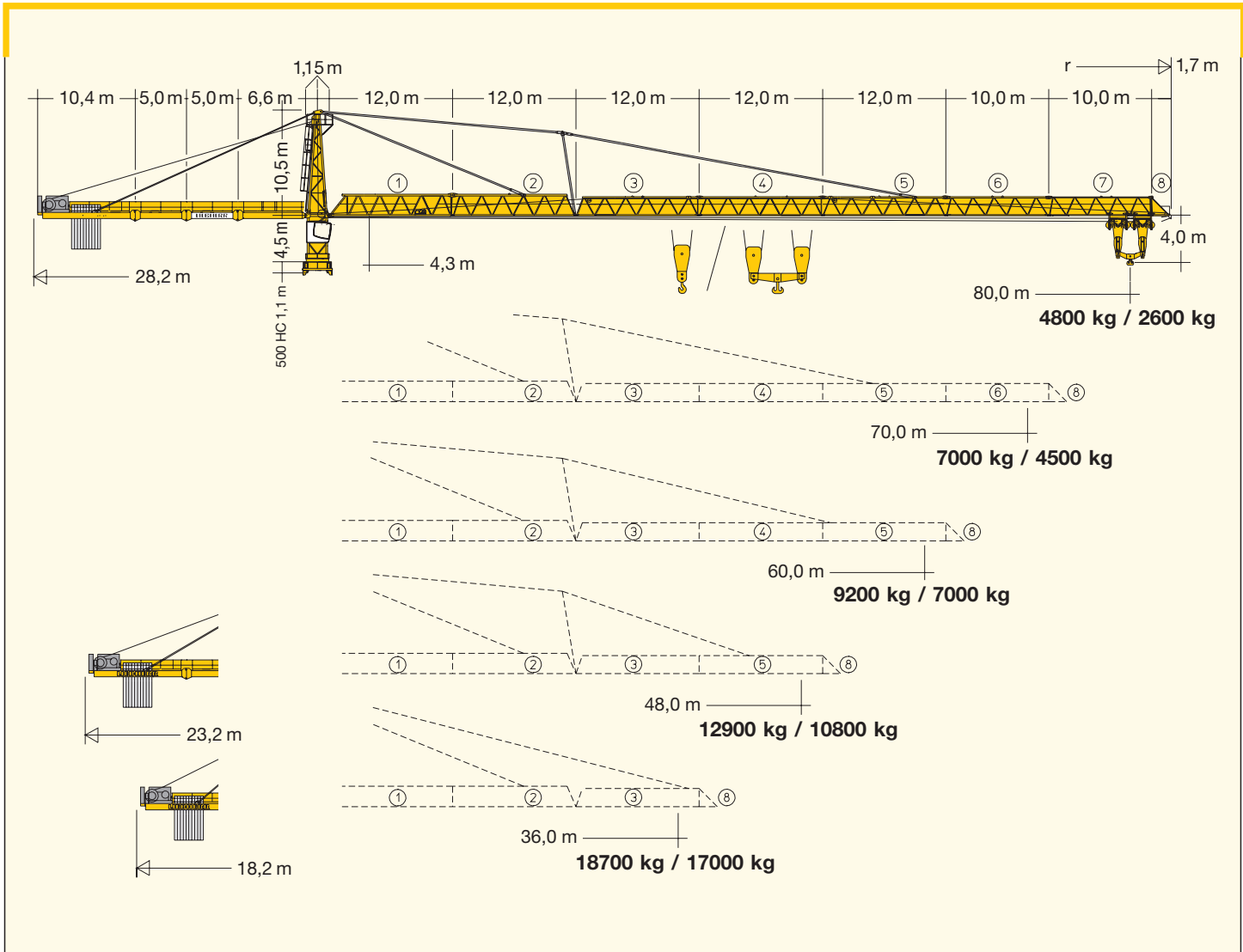

Hubhöhe

Hoisting height / Hauteur sous crochet / Altezza di sollevamento / Altura bajo gancho / Altura de montagem

500 HC		
10	59,4*	67,5*
9	53,6	61,7
8	47,8	55,9
7	42,0	50,1
6	36,2	44,3
5	30,4	38,5
4	24,6	32,7
3	18,8	26,9
2	13,0	21,1
1	7,2	15,3
0	1,4	9,5
m		

* **Weitere Hubhöhen sowie Klettern im Gebäude auf Anfrage.** / Further hoist heights and climbing in the building on request.
 Hauteurs sous crochet plus élevées et hissage dans le bâtiment sur demande. / Altre altezze di sollevamento come pure varianti di gru allungabili: su richiesta. / Para alturas bajo gancho superiores y trepado en el interior del edificio, consultar. / Outras alturas de elevação e subida no edifício: conforme ao pedido.

Ausladung und Tragfähigkeit

Radius and capacity / Portée et charge / Sbraccio e portata / Alcances y cargas / Alcance e capacidade de carga



		630 EC-H 50											
		m/kg											
m	r	m/kg	15,0	20,0	25,0	30,0	37,4	45,0	49,4	55,0	61,4	71,4	81,4
81,4 (r=83,4)	5,8-20,5 25000	25000	25000	19990	16460	12890	10410	9300	8150	7080	5780	4800	
71,4 (r=73,4)	5,8-23,5 25000	25000	25000	23310	19250	15150	12310	11040	9720	8490	7000		
61,4 (r=63,4)	5,8-25,0 25000	25000	25000	24990	20670	16300	13270	11920	10510	9200			
49,4 (r=51,4)	5,8-26,8 25000	25000	25000	25000	22240	17580	14350	12900					
37,4 (r=39,4)	5,8-28,4 25000	25000	25000	25000	23620	18700							

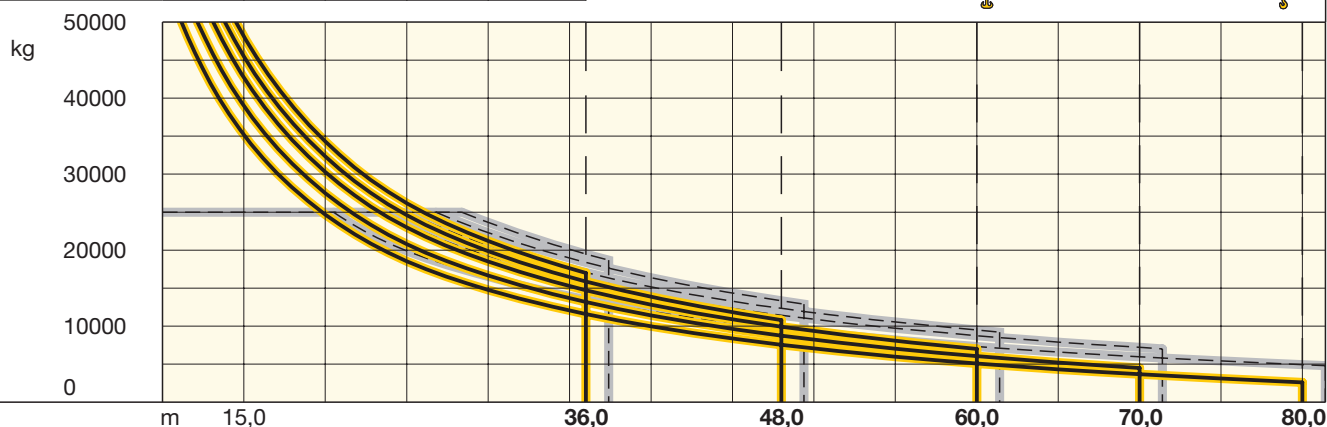

		m/kg													
m	r	m/kg	15,0	20,0	25,0	30,0	36,0	40,0	48,0	55,0	60,0	65,0	70,0	75,0	80,0
80,0 (r=83,4)	4,4-11,2 50000	35160	24690	18540	14780	11600	9990	7560	5990	5090	4330	3670	3100	2600	
70,0 (r=73,4)	4,4-12,2 50000	38980	27510	20780	16660	13180	11420	8750	7040	6060	5220	4500			
60,0 (r=63,4)	4,4-13,1 50000	42720	30280	22980	18510	14730	12820	9930	8070	7000					
48,0 (r=51,4)	4,4-13,8 50000	45490	32330	24610	19880	15880	13860	10800							
36,0 (r=39,4)	4,4-14,5 50000	48160	34310	26180	21200	17000									



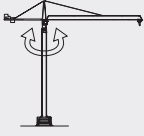
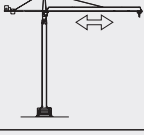
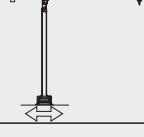





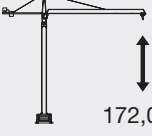





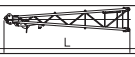

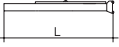





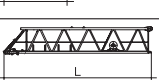

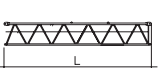
Antriebe



Driving units / Mécanismes d'entraînement / Azionamenti / Mecanismos / Mecanismos



	U/min 0,6 sl./min tr./min	2 x 10,6 kW
	Gang 1 3,0/27,0 m/min Gang 2 6,7/67,0 m/min	17,5 kW / WSB
	25,0 m/min	4 x 7,5 kW
	kVA	 110 kW 155,0















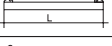

	Gang / Gear / Rapport Marcia / Velocidad / Velocidade kg	m/min
 110,0 kW Elmag, WSB WIW 300 RX 058 344,0 m 6 Lagen Layers Couches Strati Camadas Capas	1	25000 1,6 / 16,0
	2	14100 3,5 / 35,0
	3	5400 7,3 / 73,0
	4	1400 14,7 / 147,0
 172,0 m 6 Lagen Layers Couches Strati Camadas Capas	1	50000 0,8 / 8,0
	2	28900 1,7 / 17,0
	3	11500 3,6 / 36,0
	4	3400 7,3 / 73,0

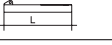
Montagegewichte: siehe Betriebsanleitung. / Erection weights: see instruction manual. / Poids de montage: voir manuel de service.
 Pesel di montaggio: vedasi le istruzioni sull'uso. / Pesos de montagem: vejãem-se es instruções p. uso. / Peso para el montaje: según manual.

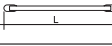
Kranoberteil		Upper part of crane / Partie supérieure de grue / Parte superiore della gru	Parte superior grúa / Parte superior do guindaste		L (m)	B (m)	H (m)	kg
Pos. Item Rep. Voice Pos. Ref.	Anz. Qty. Gta. Cant. Cant.	Drehbühne kpl. / Slewing platform cpl. Ensemble mât cabine cpl. / Piattaforma girevole compl. / Conjunto plataforma de giro Plataforma giratória compl.			6,47	3,16	2,87	21500
2	1	Turm Spitze / Tower head section / Porte-flèche Testa porta-braccio / Cabeça de apoio de lança / Cabeza de torre			10,44	1,80	2,20	6100
3	1	Gegenausleger-Kopfstück / Counter-jib head Pointe de contre-flèche / Testa di controbraccio Tramo punta de contrapluma / Cabeça de contra-lança			10,50	2,32	1,05	5800
4	1	Gegenausleger-Anlenkstück / Counter-jib heel section Pied de contre-flèche / Settore articolato di controbraccio Tramo primero-contrapluma / Base articulada da contra-lança			6,90	1,98	1,05	3300
5	2	Gegenausleger-Zwischenstück / Intermediate counter-jib section Élément intermédiaire de contre-flèche / Spezzone di controbraccio Tramo intermedio de contrapluma / Peça suplementar da contra-lança			5,20	1,90	1,05	2700
6	1	Ausleger-Anlenkstück + KAW / Jib heel section Pied de flèche / Settore articolato di braccio Base articulada de lança / Pluma tramo primero			12,31	1,98	2,34	① 6700
7	1	Ausleger-Zwischenstück / Intermediate jib section / Élément intermédiaire de flèche Spezzone di braccio / Peça suplementar da lança / Tramo intermedio pluma			12,31	1,77	2,23	② 4100
1	12,31				1,77	1,96	③ 2920	
1	12,27				1,77	1,96	④ 2650	
1	12,27				1,77	1,96	⑤ 2750	
1	10,29				1,77	1,96	⑥ 1640	
1	10,25	1,77	1,96	⑦ 1190				
8	1	Ausleger-Kopfstück / Jib head / Pointe de flèche Punta freccia / Cabeça de lança / Tramo punta de pluma			2,56	1,77	2,25	⑧ 540
9	2	Laufkatze / Trolley / Chariot de distribution Carrello / Carrito / Carro de ponte			3,25 2,90	2,02 2,02	1,83 1,83	1100 1200
10	1	Lasthaken und Traverse / Hook and cross members / Crochet et traverses Gancio e traversa / Gancho y tavessa / Gancho e traviesa			3,50	1,80	0,50	2300
11	1	Hubwerkseinheit (110 kW) / Hoist gear unit Treuil de levage / Gruppo meccanismo sollevamento Mecanismo de elevación / Grupo de mecanismo elevatório			5,90	2,85	1,80	12800
12	1	Ausleger-Abspannbock / Jib gantry Chevalet de haubange de flèche / Tirante braccio Cabalete de pluma / Cavalete de lança			8,20	1,50	0,30	810

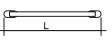
Turm		Tower / Mât / Torre	Torre / Torre						
13	10	Turmstück / Tower section / Élément de mât Elemento di torre / Torre / Torre			500 HC	6,28	2,45	2,45	6500

Klettereinrichtung		Climbing equipment / Equipement de télescopage / Attrezzatura per allungamento della gru	Equipo de trepado / Acesórios p. subida no edificio						
14	1	Führungsstück kpl., geteilt / Guide section cpl., split / Cage télescopique cpl., devisée / Gabbia di sopraelevazione compl., suddivisa / Torre de montaje, dividida / Peça de guia, subdividida			500 HC	12,39	2,75	1,58	9070
15	1	Hydraulikanlage, Stütz- und Klettertraverse / Hydraulic unit, supporting and climbing cross members / Système hydraulique avec traverses d'appui et de télescopage Sistema idraulico, traversa di appoggio e allungamento gru / Instalação hidráulica, tavessa de apoio e subida / Sistema hidráulico con traviesa de apoyo y trepado			500 HC	2,10	1,10	1,00	1100

Unterwagen		Undercarriage / Châssis / Carro della gru	Carro con mástil / Carro de guindaste						
16	4	Ausgleichsschwinge mit Schwingenlager / Pivot for wheel box Chape pour bogie / Bilanciere di equilibratura con cuscinetto bilanciante / Balancin / Balancim com suporte			500 HC	1,60	0,72	1,48	1470
17	4	Fahrschemel mit Antrieb / Rail bogie with drive Bogie moteur / Telaio con gruppo propulsore Quadro sem grupo de propulsão / Caja rodillo motriz			500 HC	1,45	0,82	0,72	1110
18	4	Fahrschemel ohne Antrieb / Rail bogie without drive Bogie fou / Telaio senza gruppo propulsore Quadro com grupo de propulsão / Caja rodillo conducido			500 HC	1,30	0,40	0,72	760
19	1	Tragholm lang / Long support arm / Longeron long Longherone lungo / Brazo largo soporte / Travessa comprida			500 HC	7,32	0,92	0,93	2330
20	2	Tragholm kurz / Short support arm / Longeron court Longherone corto / Brazo corto soporte / Travessa curta			500 HC	7,14	0,80	0,90	2135
21	4	Randträger / Border support / Traverse Supporti base / Traviesa / Apoio de bordo			500 HC	9,30	0,14	0,14	510
22	4	Stützholm / Support strut / Hauban de châssis Correnti di appoggio / Tirante vertical / Travessa de apoio			500 HC	6,98	0,26	0,34	1140
23	1	Unterwagen-Turmstück / Undercarriage tower section Mât de châssis / Elemento di torre del carro Tramo de carro / Peça de torre do chassis			500 HC	6,61	2,44	2,44	7930
24	1	Kiste mit Kleinteilen, Seilen / Crate with small parts, ropes / Caisse contenant des accessoires, câbles Cassa con minuteria, funi / Caja con piezas pequeñas, cables / Caixa com peças pequenas, cabos				2,00	1,00	1,00	2000
25	1	Abspannungen / Holding bars / Tirants Attrezzi di ancoraggio / Tirantes / Peças de ancoragem				7,60	1,00	1,00	7100

Konstruktionsänderungen vorbehalten!
 Subject to alterations! / Sous réserves de modifications!
 Si fa riserva di modifiche! / Salvo modificação da construoção!
 ¡Sujeto a modificaciones!

Sämtliche Angaben erfolgen ohne Gewähr. / This information is supplied without liability.
 Ces renseignements sont sans garantie. / Le indicazioni contenute si intendono salvo errori ed omissioni.
 Declinamos toda responsabilidad derivada de la información proporcionada. / Declinamos qualquer
 responsabilidade quanto à informação fornecida.